



# **AEFLIX BARRIER SUN INSTALLATION MANUAL**

**2023**

AeflixOÜ  
Phone: (+372) 56568285  
Address: Jõe tn 1, Kambja vald,  
61707 Tartumaa, Estonia  
E-mail: [info@aeflix.eu](mailto:info@aeflix.eu)



## Content

1	Definitions of hazards .....	4
2	Read before use.....	5
2.1	General safety.....	5
2.2	Electrical safety.....	6
2.3	Mechanical safety .....	6
2.4	Automation safety.....	7
2.5	Manufacturer liability .....	7
3	Installation of the machine.....	8
3.1	Mechanical description of the machine .....	8
3.2	Creating a foundation.....	10
3.3	Installing the tower .....	11
3.4	Beam assembly.....	12
3.5	Installing the beam.....	14
3.6	Adjusting the beam angle .....	15
3.7	Installing the solar panel.....	18
3.8	Installing the reflector post.....	19
3.9	Installing the battery .....	20

AeflixOÜ  
Phone: (+372) 56568285  
Address: Jõe tn 1, Kambja vald,  
61707 Tartumaa, Estonia  
E-mail: info@aeflix.eu

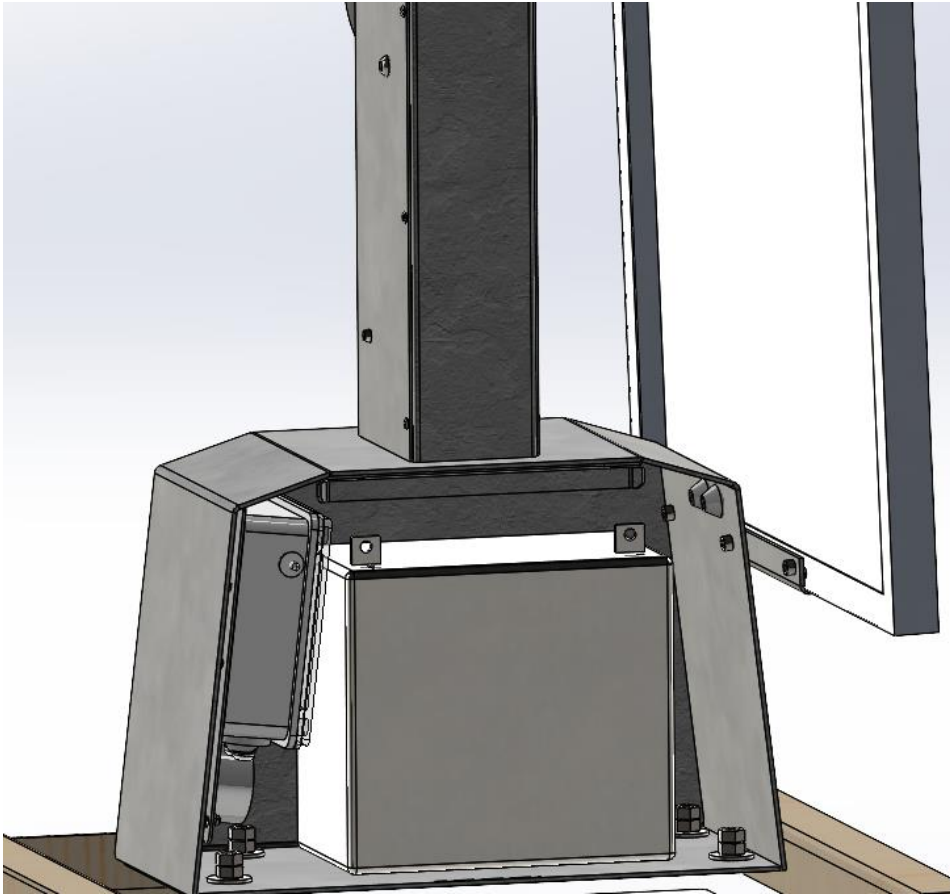

..... 20

3.10 Description of the barrier technical parameters ..... 21

# 1 Definitions of hazards

The following pictograms appear in the manual:



## **CAUTION!**

This term and symbol will be used if non-compliance with safety information can result in bodily injury or death. Used also when it can end with significant damage to the machine.



## **ATTENTION!**

This term and symbol are used to indicate to minor injury or other consequential damages resulting from use.

## 2 Read before use



### **CAUTION!**

These devices may only be used by trained personnel. The user must always follow the operating instructions, safety instructions, safety labels and instructions for safe handling of the device. Persons who do not have the necessary training are a danger to themselves and to the equipment.

**IMPORTANT!** The operator of the device must be familiar with all warnings, cautions, and instructions before using the device. Before starting work on the equipment, the owner of the equipment must make sure that the fitters and operators of the machine have read both the safety and operating instructions for the equipment and the maintenance manual. The main responsibility for ensuring safe operation of the equipment lies with the owner of the equipment and the individuals who use it

All machinery involves hazards due to rotating bodies, belts and pulleys, high voltage, noise and compressed air. When using the equipment, safety precautions must be observed to prevent injuries to persons and damage to the equipment.



**CAUTION!** It is strictly forbidden to be in the work area or on work surfaces when the device is running, as this could result in serious injury or death. Machines can move if the emergency stop button is not pressed.

### 2.1 General safety

- This device can cause serious injuries.
- Read local safety instructions before starting work. If you have any safety questions, contact your machine dealer.



### **ATTENTION!**

- Security covers must be kept closed and locked when the device is running.

## 2.2 Electrical safety

- Supply voltage must correspond to manufacturer specifications. Machine use with improper supply voltage may result in damages to machines and operators.
- Electrical cabins must be locked at all times, with exception to assembly and maintenance work. Assembly and maintenance work can only be performed by professionals. If the main switch is turned on some of the components may be at an energized state, some of the components work at a high temperature. After assembly and maintenance electrical cabinets must be locked. Access to these cabinets may only be granted to authorised personnel.
- Don't press the start and/ or restart buttons before the machine is fully assembled.

## 2.3 Mechanical safety



### **CAUTION!**

- Before using the machine, make sure that it is undamaged. Damaged parts must be repaired or replaced by qualified technicians. Machines must not be used if the machine components are not working properly.
  - Improperly installed parts can detach from the machine and cause injury or death to users and / or the machine.
- All machine parts must be serviced in accordance with the maintenance instructions.

## 2.4 Automation safety



### **ATTENTION!**

This device is designed to work semiautomatically, but might not be safe without surveillance. Machine owner is responsible of safe and proper operation of the machine in unsurveilled operation.

## 2.5 Manufacturer liability

All devices have been designed and built using the best technologies and follow the current requirements for machine safety.

The manufacturer is not responsible for human injury or death, material and financial losses if they are caused by the following reasons:

- Improper use of the machine.
- Incorrect installation, use and maintenance of the machine.
- Using machines with damaged, wrongly installed and/or not working safety devices.
- Not fulfilling the safety requirements established in the user guide.
- Non authorized modification of machines and/or machine parts without proper coordination with the manufacturer.
- Incorrectly replaced spare parts or using spare parts not approved by the manufacturer.
- Damage retained by foreign objects or unforeseeable circumstances.

## 3 Installation of the machine

### 3.1 Mechanical description of the machine

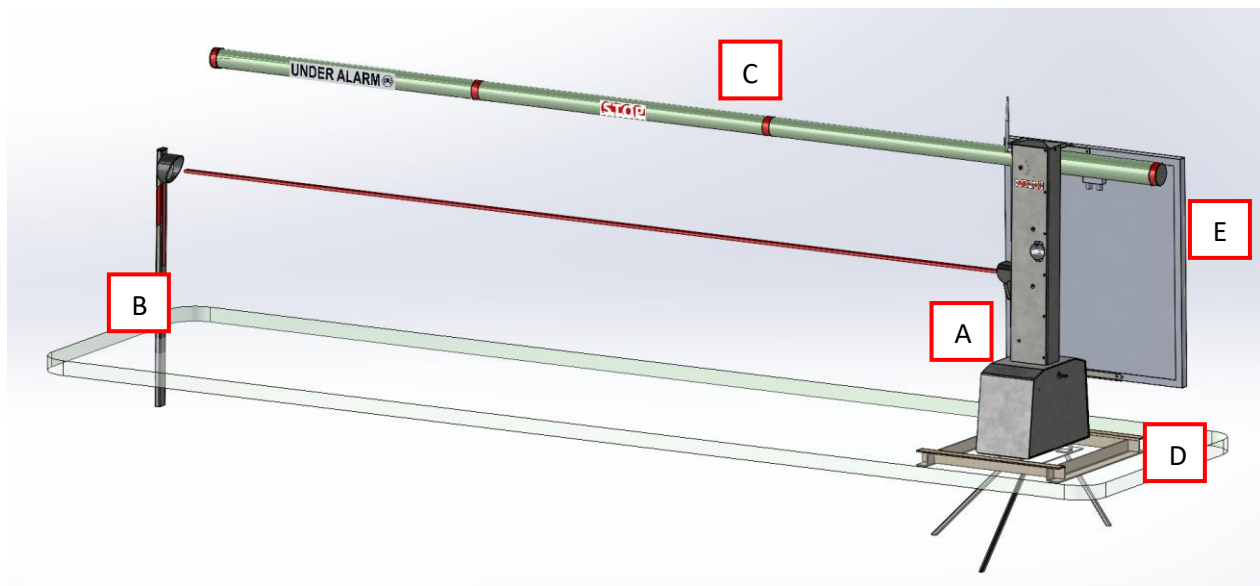

**Figure 1.** Illustration of the machine.

The machine is a semiautomatic road barrier, which can be operated automatically via phone and manually with a key in case of power loss.





The barrier consists of five parts which have to be installed on the site:

A – Tower – the tower holds all the mechanics and electronic of the machine.

B – Reflector post

C – Beam

D – Foundation

E – Solar panel

## 3.2 Creating a foundation

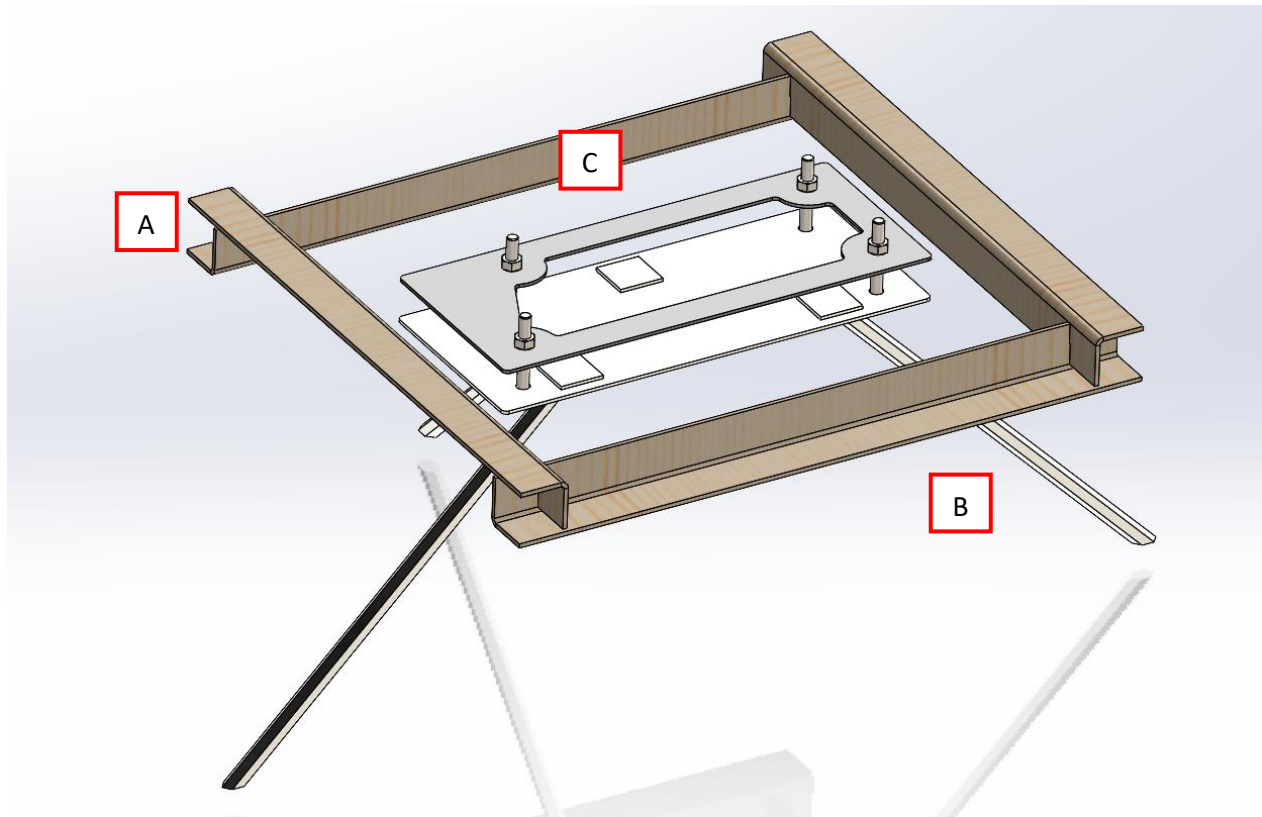

**Figure 2.** Illustration of the foundation.

The foundation kit consists of foundation mold (A), reinforcement pikes (B), underframe (C). Prepare the location of the foundation to suite pouring cement. Place the foundation mold (A) in the prepared area. Place the underframe (C) inside the foundation mold (A), so that the underframe (C) is centered to the mold (A) and the top plastic plate of the underframe (C) is on the same level as the top of the mold (A). Hammer in the reinforcement spikes (B) through the holes in the underframe (C) at a 45 degree angle, so that they facing away from each other. Fill the mould (A) with ~10L (~25kg) of cement and let it harden to the specification of the producer. Remove the nuts on the bolts after cement is cured.

## 3.3 Installing the tower

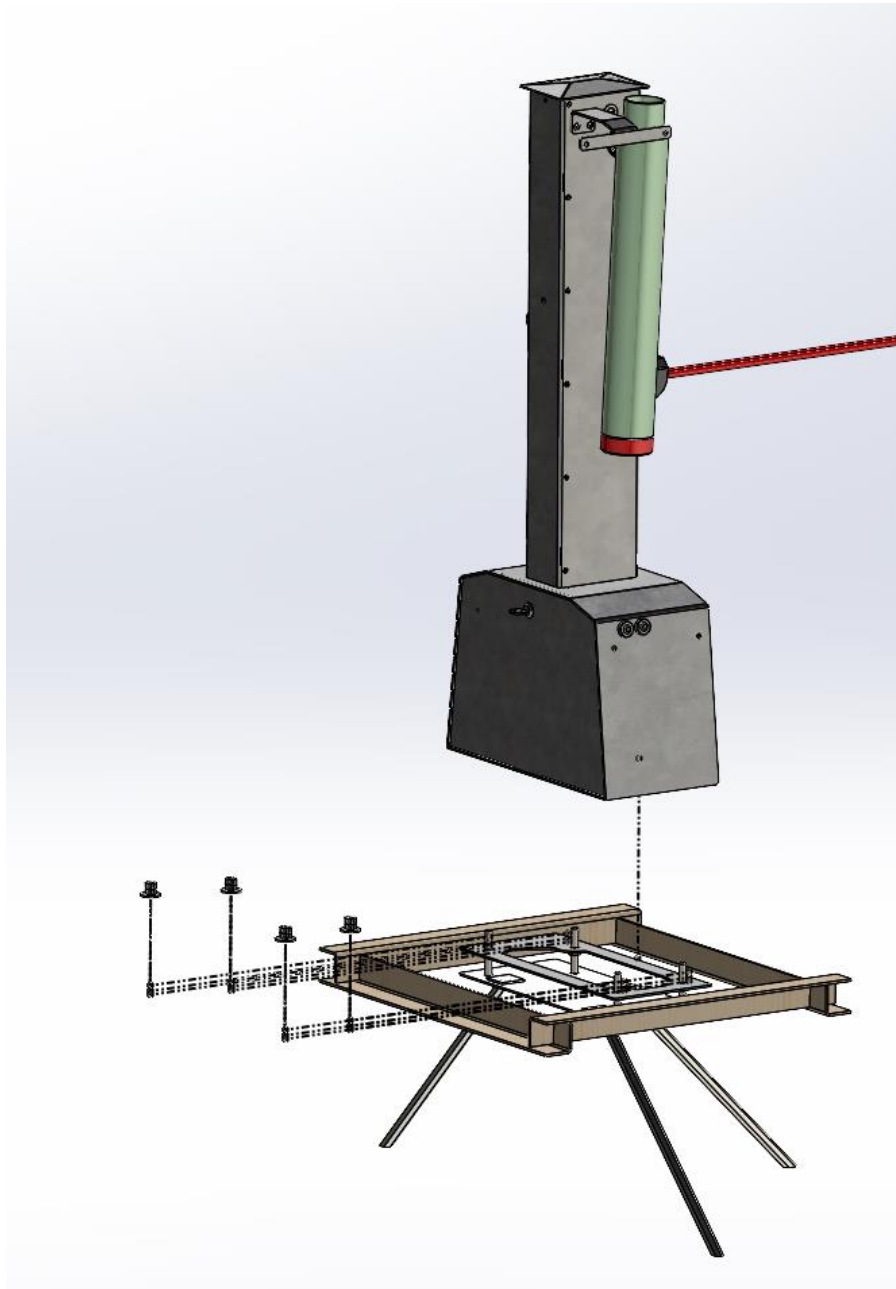
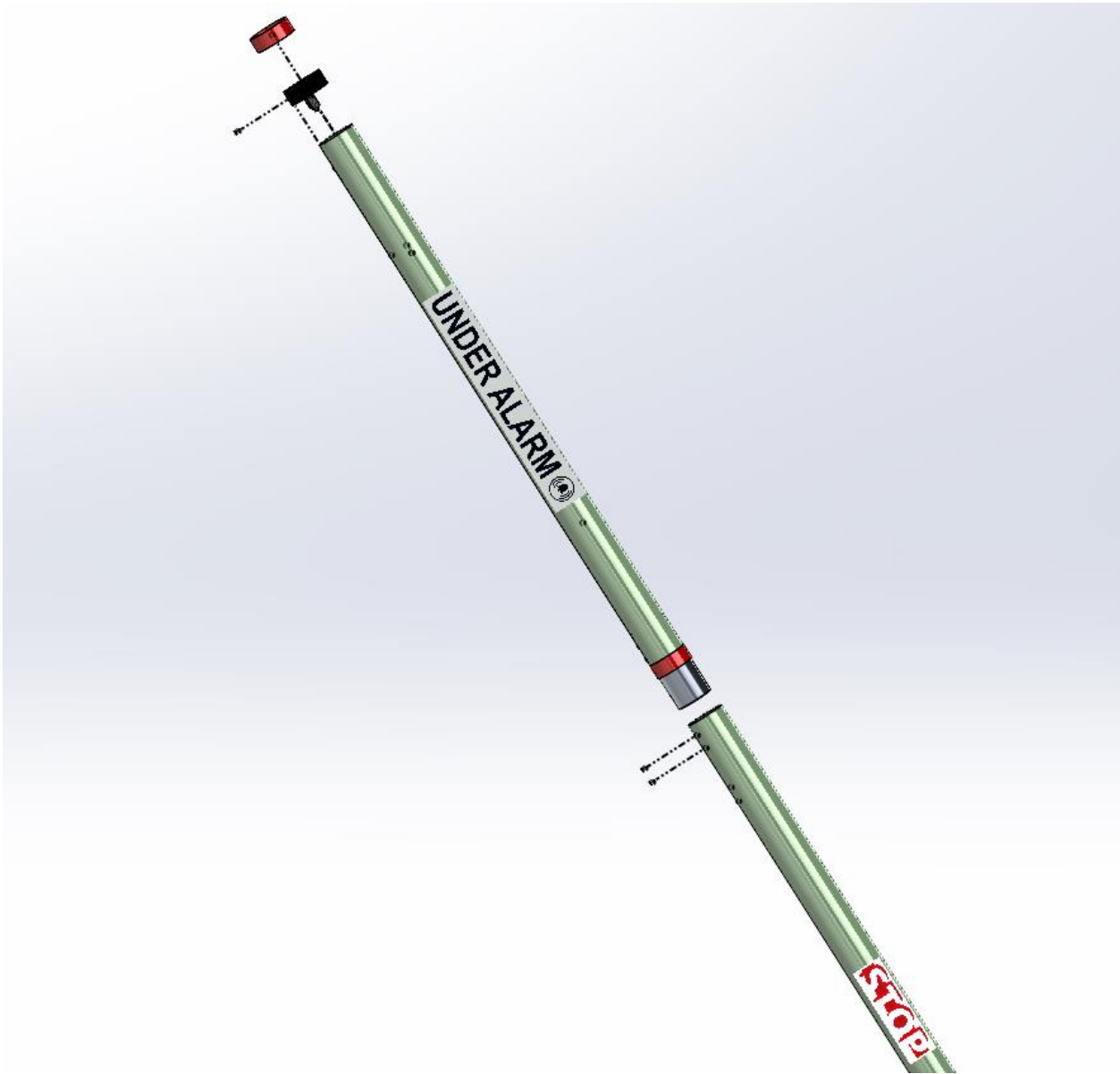

**Figure 3.** Assembly of the tower

Place the tower on the foundation and fix it to the foundation by 4 M10 nuts with 4 washers.

AeflixOÜ  
Phone: (+372) 56568285  
Address: Jõe tn 1, Kambja vald,  
61707 Tartumaa, Estonia  
E-mail: info@aeflix.eu

## 3.4 Beam assembly



**Figure 4.** Beam assembly – 1 (post assembly side cut – see next page)

Connect two beam segments together and use provided rivets with riveting tool to fix the parts together.  
Add the endcap and screw M6 bolt to hole

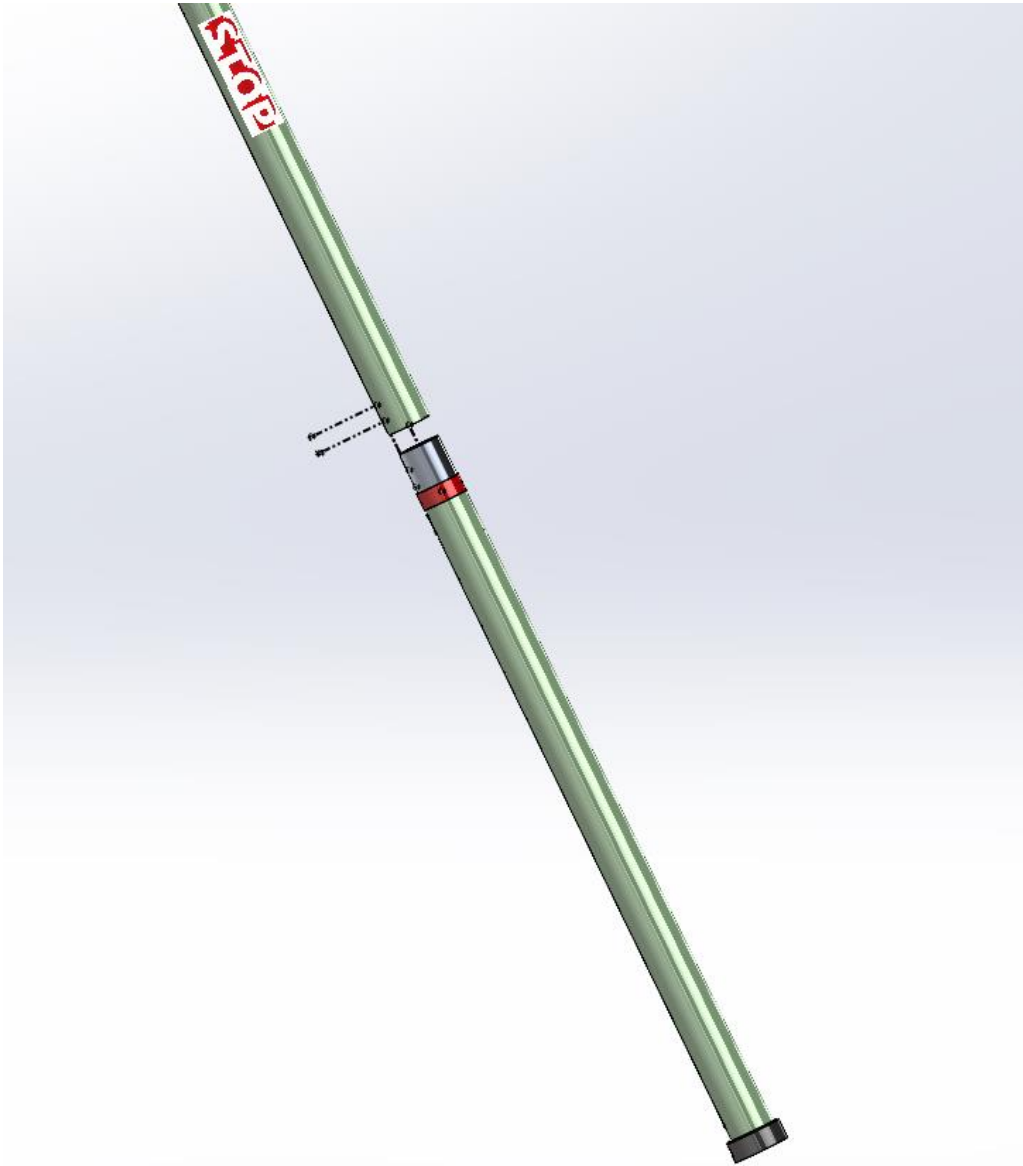

**Figure 5.** Beam assembly – 2 (reflector assembly side cut – see previous page)

Connect two beam segments together and use provided rivets with riveting tool to fix the parts together.

## 3.5 Installing the beam

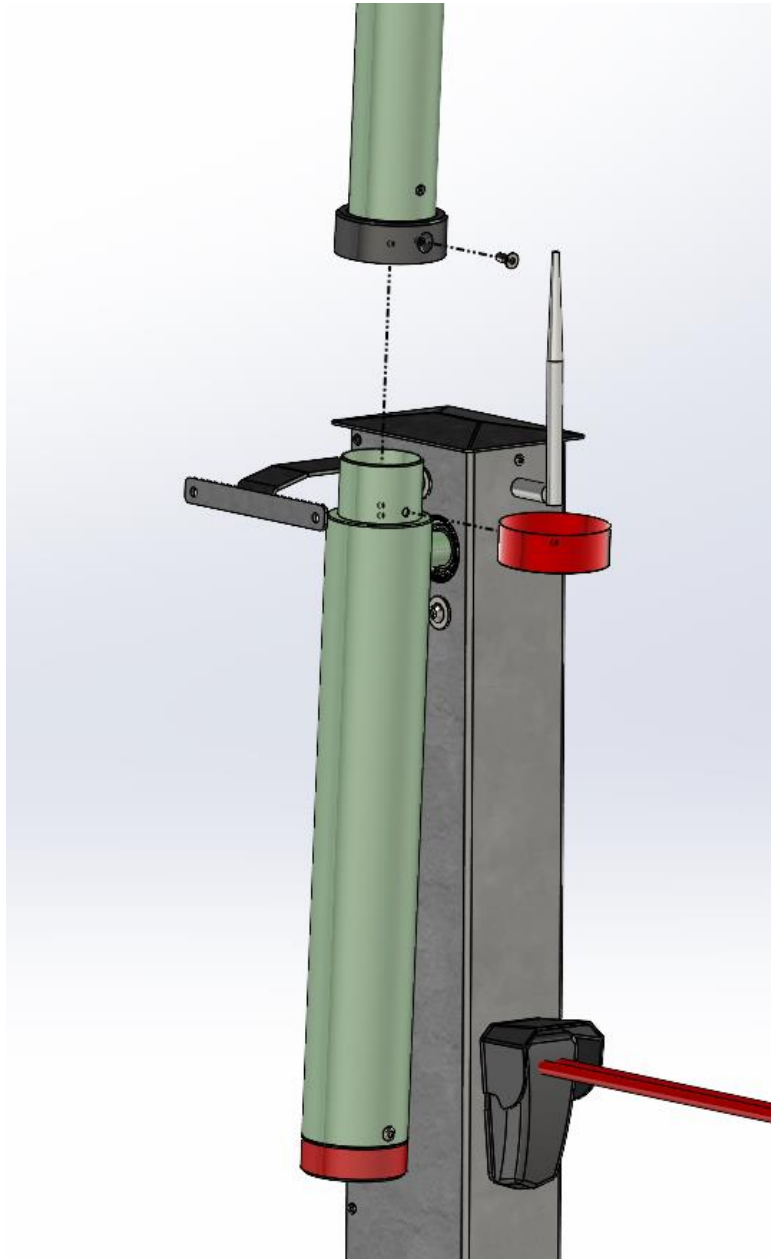

**Figure 6.** Installation of the beam

Push the beam on the counterweight bar and fix it with M6 bolt. When the beam is fixed, wrap a red reflector around the black plastic part where the bolt was inserted.

## 3.6 Adjusting the beam angle

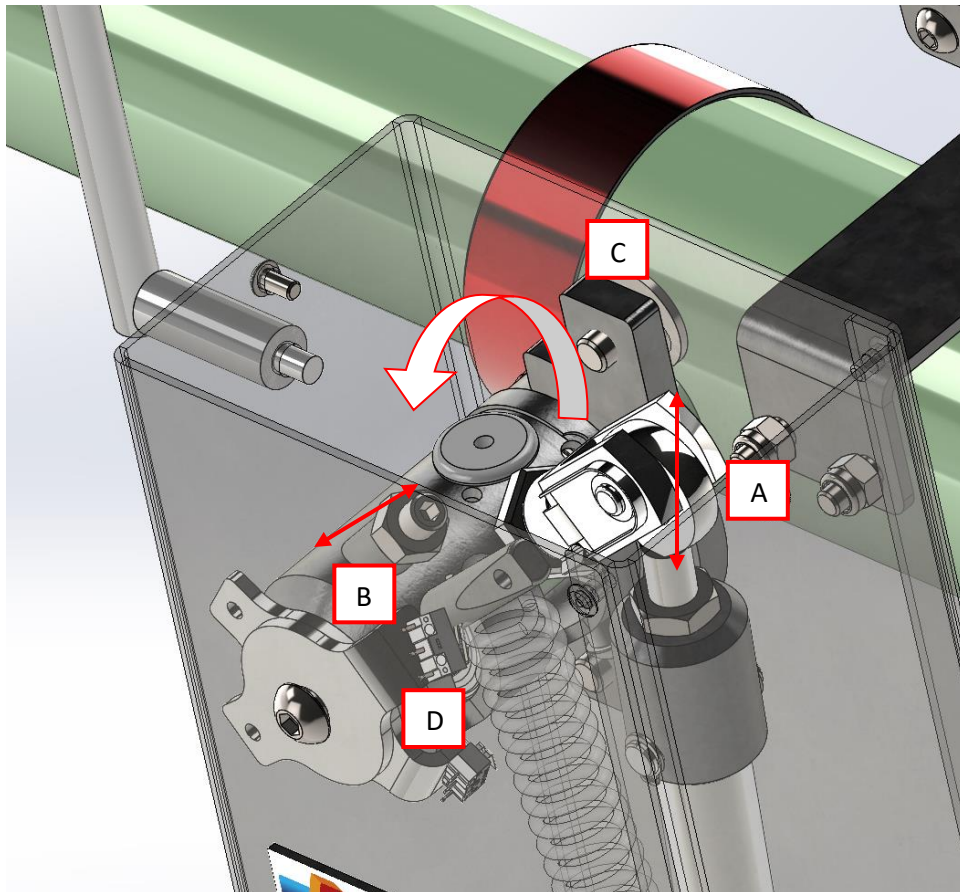

**Figure 7.** Beam adjustment

Lowering:

1. Untighten 3 M8 bolts which hold the hub (C) in place
2. Release the nut holding the rod end in place (A)
3. Release the clevis (fork near A) locking pin and remove the pin. NB! the beam wants to rise when the clevis pin is removed, so hold it in place firmly!
4. Turn the rod end (A) half a turn counter clockwise.



5. Reinstall the clevis locking pin – since the hub bolts were untightened, the hub (C) should also turn slightly counter clockwise. If the beam angle is still too high, repeat process in point 4.
6. Re tighten the rod end (A) nut and 3 M8 bolts when desired angle has been reached.





#### Lifting:

1. Untighten 3 M8 bolts which hold the hub (C) in place
2. Release the nut holding the rod end in place (A)
3. Release the clevis (fork near A) locking pin and remove the pin. NB! the beam wants to rise when the clevis pin is removed, so hold it in place firmly!
4. Turn the rod end (A) half a turn clockwise.
5. Reinstall the clevis locking pin. If the beam angle is still too low, repeat process in point 4.
6. The hub (C) must be turned slightly clockwise, so that there isn't any gap between the clevis axle and the hub slot.
7. Re tighten the rod end (A) nut and 3 M8 bolts when desired angle has been reached.

#### Vertical adjustment can be done by:

1. Releasing the setscrew nut (B) and turning the setscrew (B) counter clockwise for higher beam angle. Re tighten the setscrew nut after adjustment is complete.
2. Releasing the setscrew nut (B) and turning the setscrew (B) clockwise for lower beam angle. Re tighten the setscrew nut after adjustment is complete.

#### End switch adjustment:

1. Release M8 bolt, so that end switch mounts (D) will move freely.
2. Adjust end switches so that barrier beam motor switches of before reaching both end points.
3. Tighten the M8 bolt, released in the first step.

## 3.7 Installing the solar panel

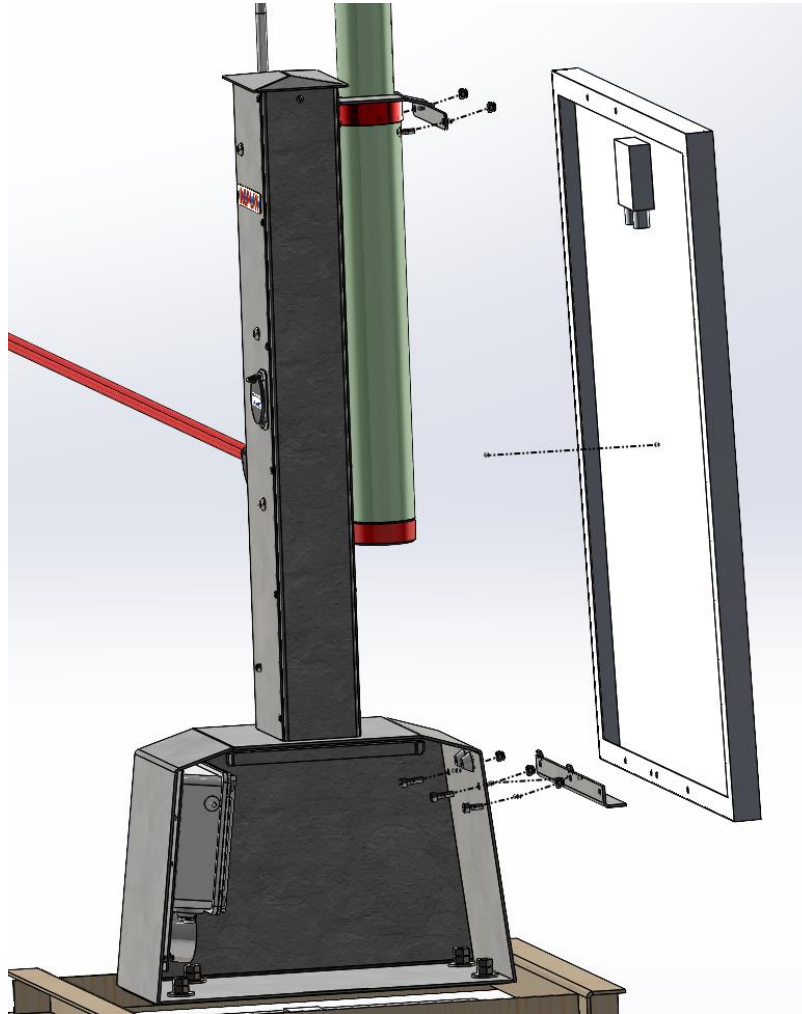

**Figure 8.** Installation of solar panel

Put the solar panel on the solar panel harness and fix it with 4 M6 bolts and locking nuts. Connect the solar panel cable.

## 3.8 Installing the reflector post

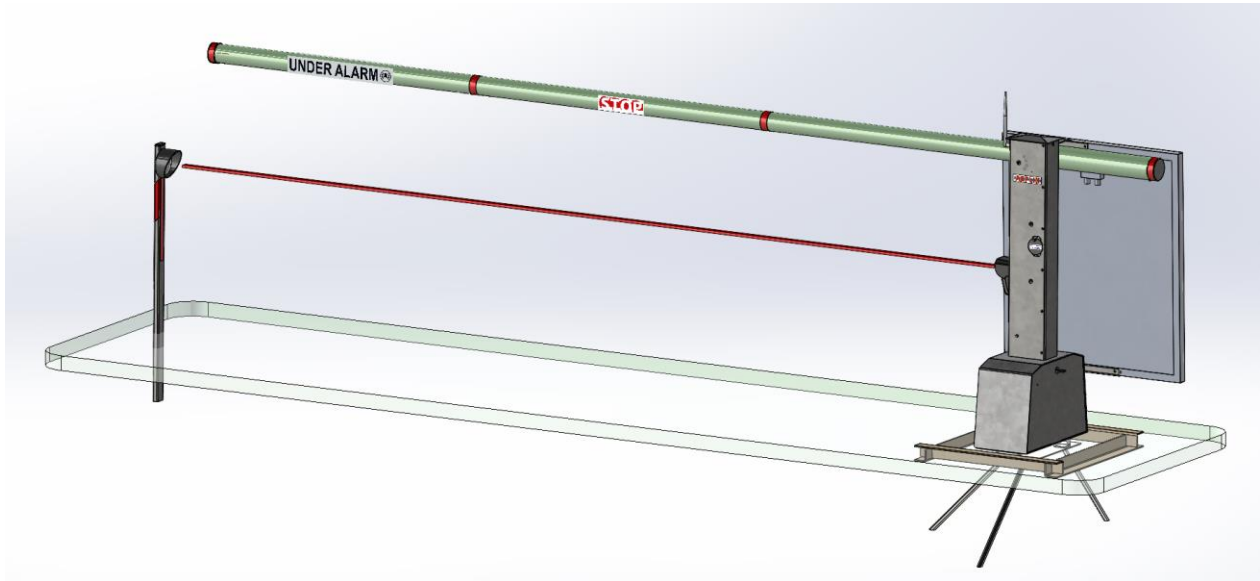

**Figure 9.** Installation of reflector post

Reflector post is pushed into the ground. It has to be centered to the tower and centered vertically to the photo sensor. The default center height of the reflector from ground is 570mm.

## 3.9 Installing the battery

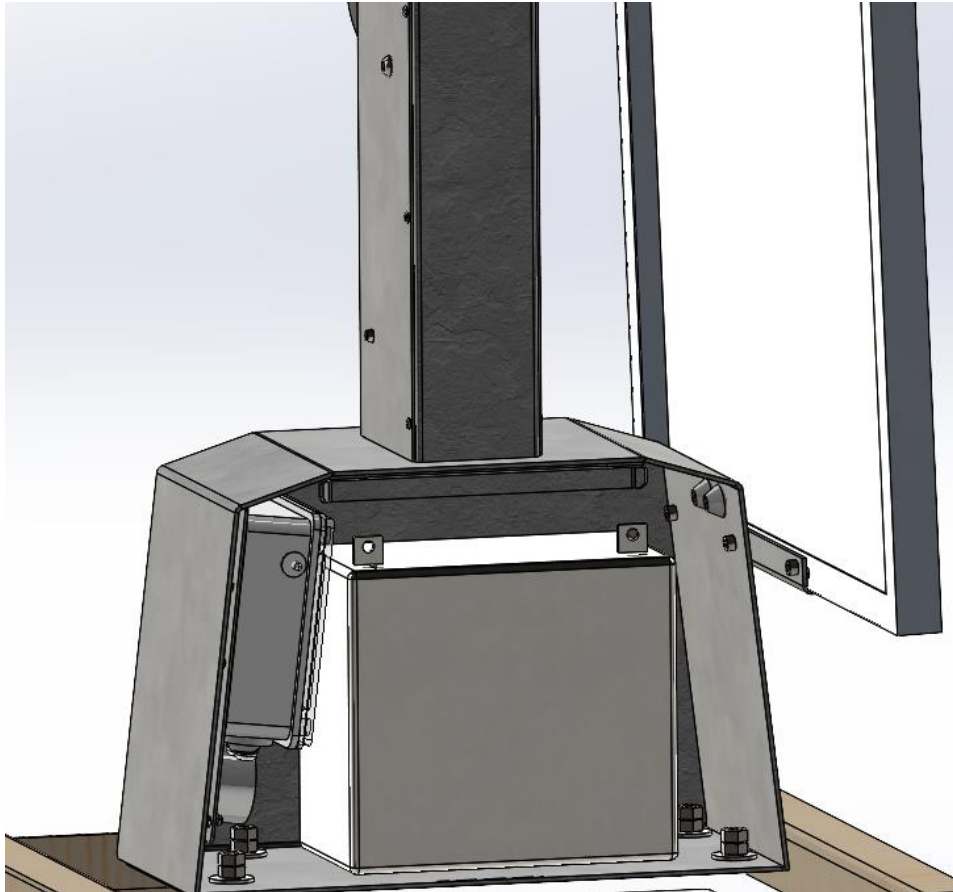

**Figure 10.** Installing the battery.

Install the battery with protective sleeve inside the compartment under the tower. Connect the power wires to battery terminals. Pay attention to the polarity of the battery.



### 3.10 Description of the barrier technical parameters

**Table 1.** Technical parameters

<b>Parameters</b>	<b>Value</b>	<b>Unit</b>
Height	1030	mm
Height of antenna	1066	mm
Width of base	420	mm
Width with panel	600	mm
Lenght of base	216	mm
Lenght with panel	667	mm
Lenght of the beam	3120	mm
Height of beam from ground	910	mm
Weight of machine	60	kg



## Contact

**In case of questions or problems, please contact us.**

Call us:

(+372) 56568285

Write us an e-mail:

info@aeflix.eu

Write us:

AeflixOÜ

Jõe tn 1, Reola küla, Kambja vald 61707 Tartumaam Estonia

**Our company is here to solve your problems.**

