



AEFLIX BARRIER WITH BENT PROFILE

INSTALLATION MANUAL

2021

1

Aeflix OÜ
Phone: (+372) 56568285
Address: Jõe tn 1, Kambja vald
61707 Tartumaa, Estonia
E-mail: info@aeflix.eu



Content

1	Definitions of hazards.....	3
2	Read before use.....	4
2.1	General safety.....	4
2.2	Mechanical safety.....	5
2.3	Manufacturer liability.....	5
3	Installation of the machine.....	6
3.1	Mechanical description of the machine.....	6
3.2	Creating a foundation.....	7
3.3	Installing the tower.....	8
3.4	Beam assembly.....	9
3.5	Installing the beam.....	11
3.6	Adjusting the beam angle.....	12
3.7	Description of the barrier technical parameters.....	14

1 Definitions of hazards

The following pictograms appear in the manual:



CAUTION!

This term and symbol will be used if non-compliance with safety information can result in bodily injury or death. Used also when it can end with significant damage to the machine.



ATTENTION!

This term and symbol are used to indicate to minor injury or other consequential damages resulting from use.

2 Read before use



CAUTION!

These devices may only be used by trained personnel. The user must always follow the operating instructions, safety instructions, safety labels and instructions for safe handling of the device. Persons who do not have the necessary training are a danger to themselves and to the equipment.

IMPORTANT! The operator of the device must be familiar with all warnings, cautions, and instructions before using the device. Before starting work on the equipment, the owner of the equipment must make sure that the fitters and operators of the machine have read both the safety and operating instructions for the equipment and the maintenance manual. The main responsibility for ensuring safe operation of the equipment lies with the owner of the equipment and the individuals who

All machinery involves hazards due to rotating bodies, belts and pulleys, high voltage, noise and compressed air. When using the equipment, safety precautions must be observed to prevent injuries to persons and damage to the equipment.

2.1 General safety

- This device can cause serious injuries.
- Read local safety instructions before starting work. If you have any safety questions, contact your machine dealer.



ATTENTION!

- Security covers must be kept closed and locked when the device is running.

2.2 Mechanical safety



CAUTION!

- Before using the machine, make sure that it is undamaged. Damaged parts must be repaired or replaced by qualified technicians. Machines must not be used if the machine components are not working properly.
- Improperly installed parts can detach from the machine and cause injury or death to users and / or the machine.
- All machine parts must be serviced in accordance with the maintenance instructions.

2.3 Manufacturer liability

All devices have been designed and built using the best technologies and follow the current requirements for machine safety.

The manufacturer is not responsible for human injury or death, material and financial losses if they are caused by the following reasons:

- Improper use of the machine.
- Incorrect installation, use and maintenance of the machine.
- Using machines with damaged, wrongly installed and/or not working safety devices.
- Not fulfilling the safety requirements established in the user guide.
- Non authorized modification of machines and/or machine parts without proper coordination with the manufacturer.
- Incorrectly replaced spare parts or using spare parts not approved by the manufacturer.
- Damage retained by foreign objects or unforeseeable circumstances.

3 Installation of the machine

3.1 Mechanical description of the machine

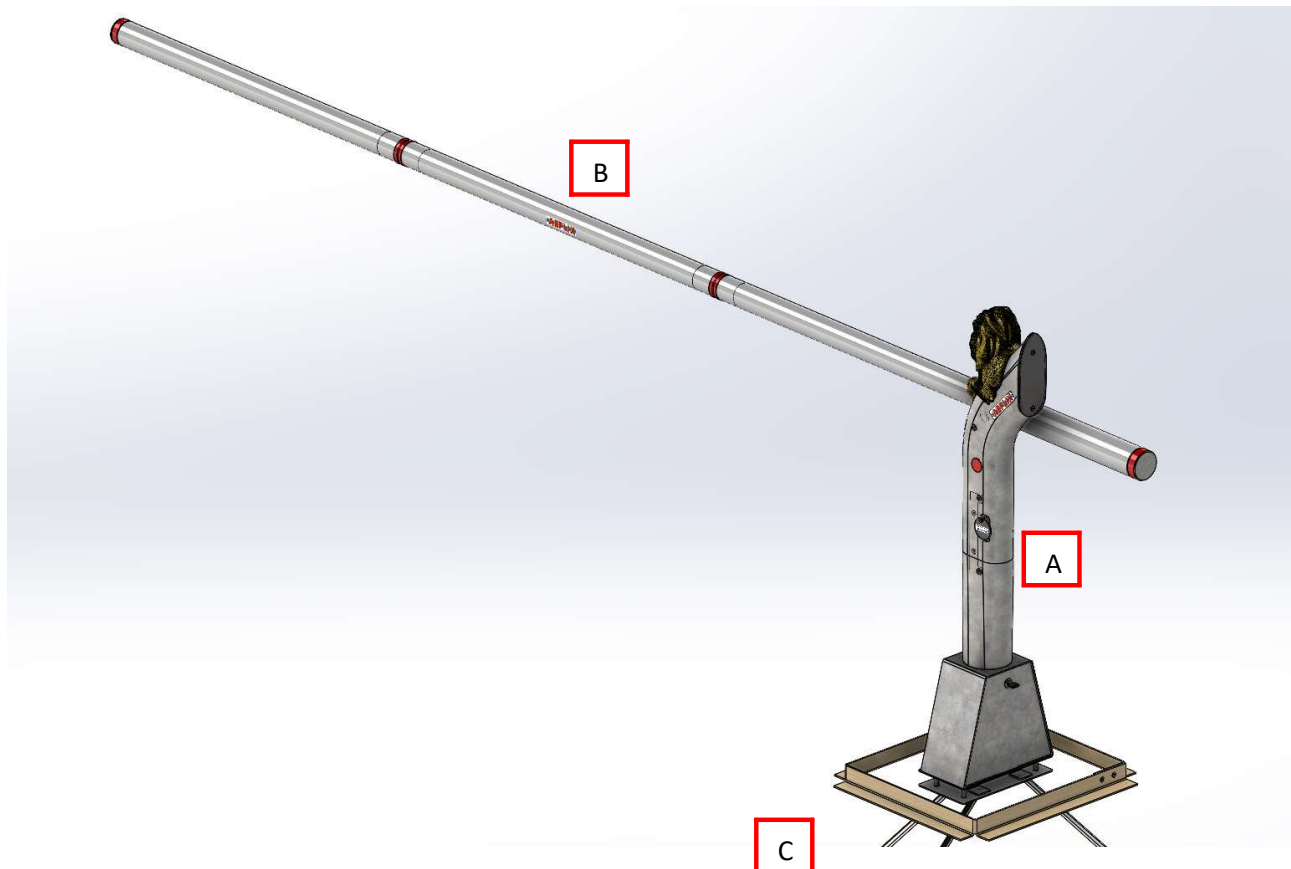

Figure 1. Illustration of the machine.

The machine is a manual road barrier, which can be operated by unlocking the mechanism with a key and lifting/lowering the beam.

A – Tower

B – Beam

C – Foundation

6

3.2 Creating a foundation

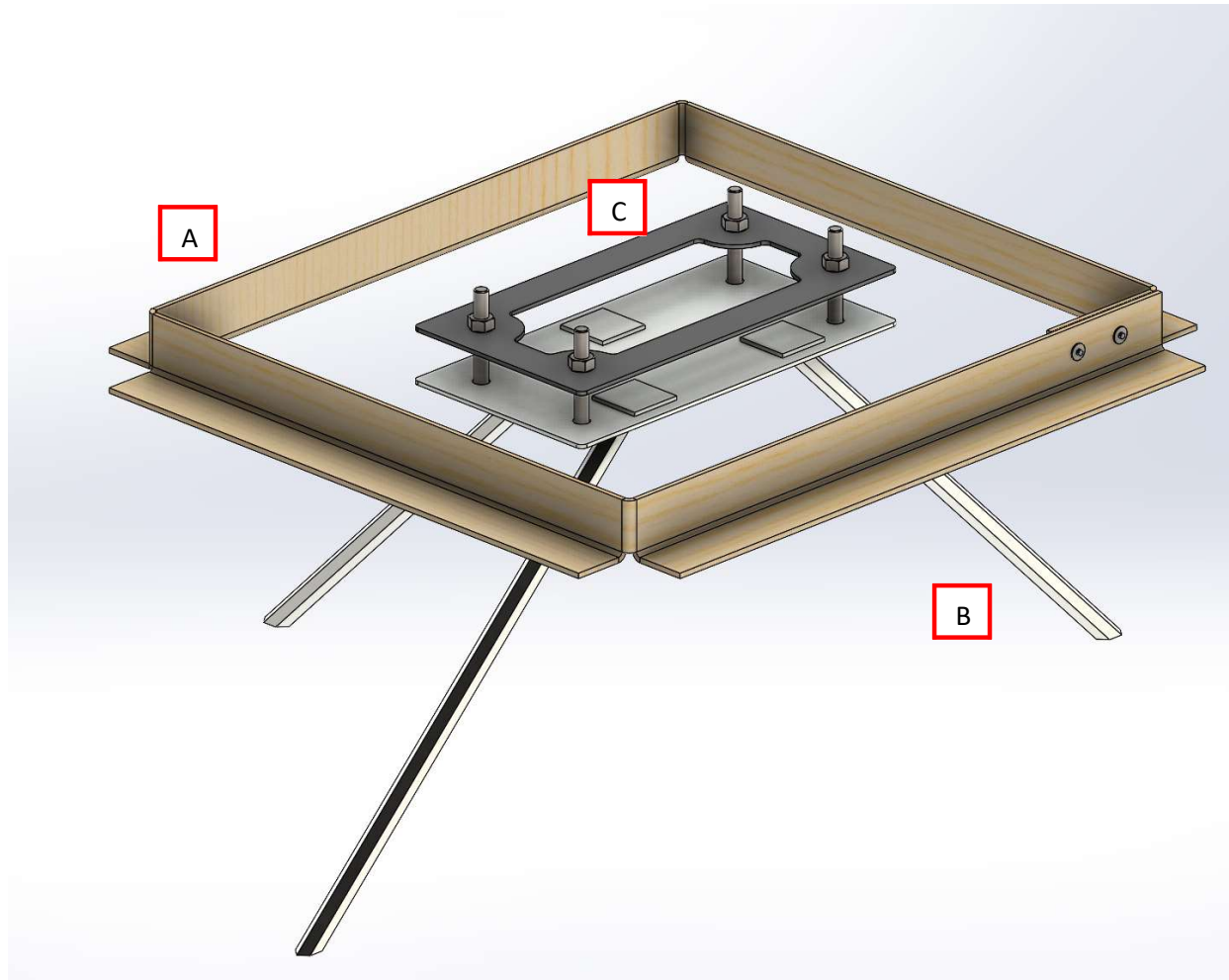

Figure 2. Illustration of the foundation.

The foundation kit consists of foundation mold (A), reinforcement pikes (B), underframe (C). Prepare the location of the foundation to suite pouring cement. Place the foundation mold (A) in the prepared area. Place the underframe (C) inside the foundation mold (A), so that the underframe (C) is centered to the mold (A) and the top plastic plate of the underframe (C) is on the same level as the top of the mold (A). Hammer in the reinforcement spikes (B) throught the holes in the underframe (C) at a 45 degree angle, so that they facing away from each other. Fill the mould (A) with ~10L (~25kg) of cement and let it harden to the specification of the producer. Remove the nuts on the bolts after cement is cured.

3.3 Installing the tower

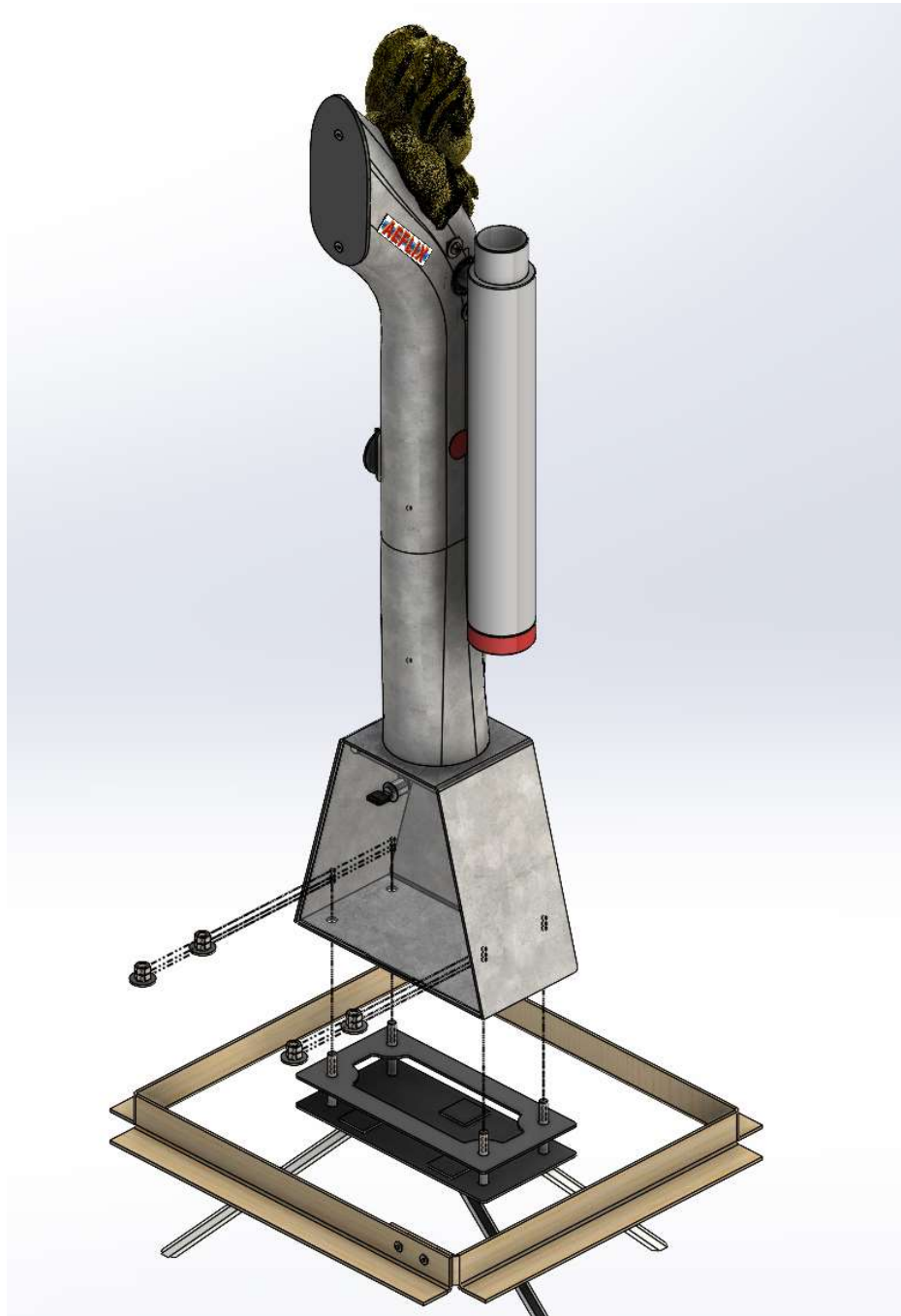

Figure 3. Assembly of the tower

Place the tower on the foundation and fix it to the foundation by 8 M10 nuts with 4 washers.

Aeflix OÜ
Phone: (+372) 56568285
Address: Jõe tn 1, Kambja vald
61707 Tartumaa, Estonia
E-mail: info@aeflix.eu

3.4 Beam assembly



Figure 4. Beam assembly – 1 (post assembly side cut – see next page)

Connect two beam segments together and use provided rivets with riveting tool to fix the parts together.



10
Figure 5.

Beam assembly – 2 (reflector assembly side cut – see previous page)

Aeflix OÜ
Phone: (+372) 56568285
Address: Jõe tn 1, Kambja vald
61707 Tartumaa, Estonia
E-mail: info@aeflix.eu



Connect two beam segments together and use provided rivets with riveting tool to fix the parts together.

3.5 Installing the beam



Figure 6. Installation of the beam

Push the beam on the counterweight bar and fix it with M6 bolt. When the beam is fixed, wrap a red reflector around the black plastic part where the bolt was inserted.

3.6 Adjusting the beam angle

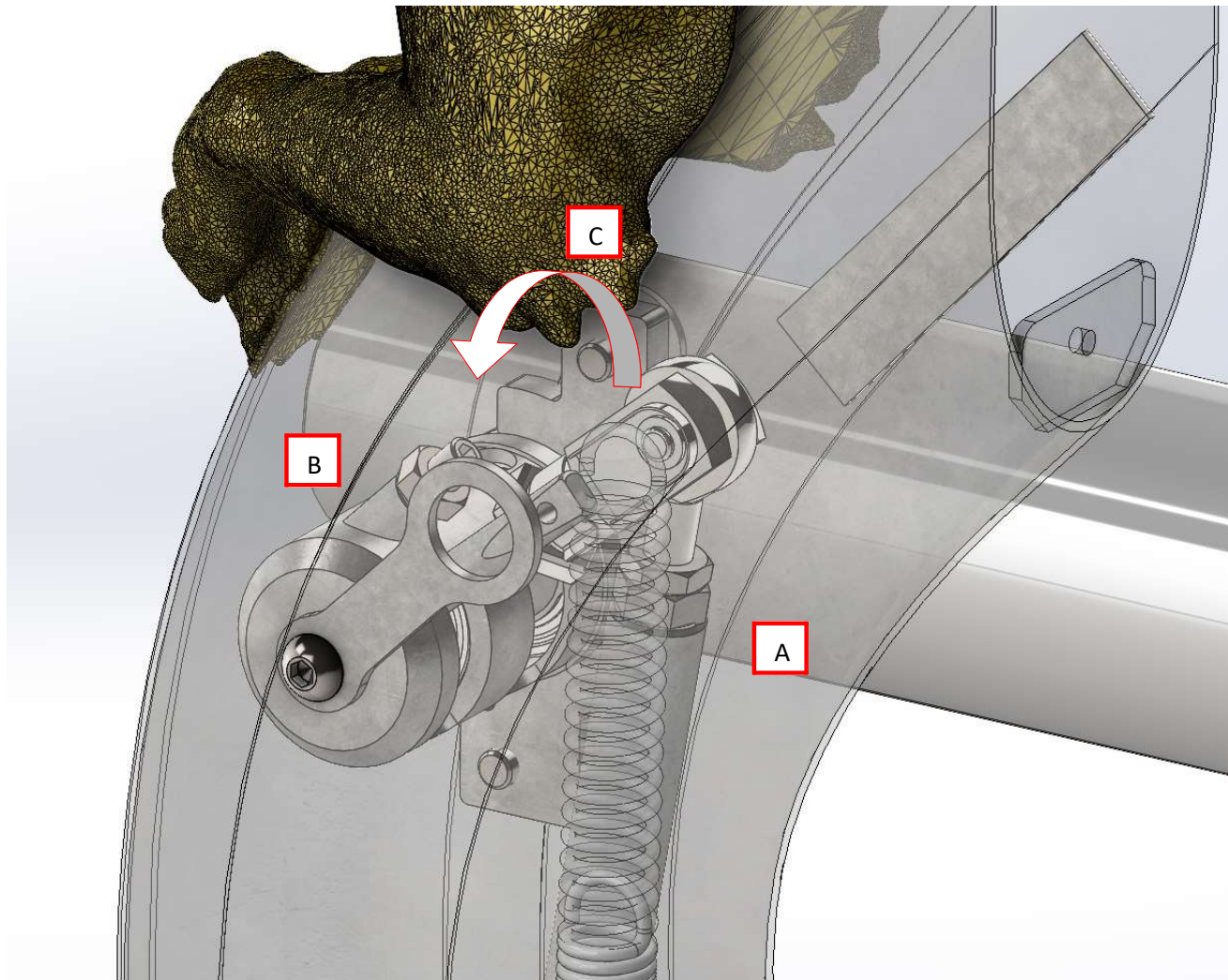

Figure 7. Beam adjustment

Lowering:

1. Untighten 3 M8 bolts which hold the hub (C) in place
2. Release the nut holding the rod end in place (A)
3. Release the clevis (fork near A) locking pin and remove the pin. NB! the beam wants to rise when the clevis pin is removed, so hold it in place firmly!
4. Turn the rod end (A) half a turn counter clockwise.
5. Reinstall the clevis locking pin – since the hub bolts were untightened, the hub (C) should also turn slightly counter clockwise. If the beam angle is still too high, repeat process in point 4.
6. Re tighten the rod end (A) nut and 3 M8 bolts when desired angle has been reached.

13



Lifting:

1. Untighten 3 M8 bolts which hold the hub (C) in place
2. Release the nut holding the rod end in place (A)
3. Release the clevis (fork near A) locking pin and remove the pin. NB! the beam wants to rise when the clevis pin is removed, so hold it in place firmly!
4. Turn the rod end (A) half a turn clockwise.
5. Reinstall the clevis locking pin. If the beam angle is still too low, repeat process in point 4.
6. The hub (C) must be turned slightly clockwise, so that there isn't any gap between the clevis axle and the hub slot.
7. Re tighten the rod end (A) nut and 3 M8 bolts when desired angle has been reached.

Vertical adjustment can be done by:

1. Releasing the setscrew nut (B) and turning the setscrew (B) counter clockwise for higher beam angle. Re tighten the setscrew nut after adjustment is complete.
2. Releasing the setscrew nut (B) and turning the setscrew (B) clockwise for lower beam angle. Re tighten the setscrew nut after adjustment is complete.

3.7 Description of the barrier technical parameters

Table 1. Technical parameters

Parameters	Value	Unit
Height	1210	mm
Width of base	300	mm
Length of base	150	mm
Length of the beam	3120	mm
Height of beam from ground	860	mm
Weight of machine	30	kg



Contact

In case of questions or problems, please contact us.

Call us:

(+372) 56568285

Write us an e-mail:

info@aeflix.eu

Write us:

Aeflix OÜ

Jõe tn 1, Reola küla, Kambja vald, 61707 Tartumaa, Estonia

